

# CCL 50 SERIES

## SIZED DOOR CLOSER

**CCL**

This closer is the choice of architectural aluminum specialists who demand long-lasting and reliable operation of moderate to high traffic commercial storefront doors. Made from the highest quality alloys and metals, 50 series closers are designed to provide stable closing force even under extreme conditions.



- Non handed
- Sized 2, 3, 4 and 5
- Universal retrofit hole spacing
- Power adjustable arm bracket
- Maximum 180° opening angle
- Precision cast aluminum alloy housing
- Rack and pinion mechanism

- Non critical thermostatic valves
- High quality non gumming and non freezing hydraulic fluid
- Separate adjustable sweep and latching speed valves
- Optional adjustable hold open function from 90°- 170°

- Optional adjustable back check control from 70°- 85°
- Finishes: metallic aluminum or dark bronze
- Made in Japan
- Complies with CGSB-69-GP2M/10M/11M
- cUL and UL listed
- 10 year limited warranty



# 01.010

# CCL 50 SERIES DOOR CLOSER

## SPECIFICATION

Closers for interior and exterior doors shall be CCL 50 Series full rack and pinion type with cast aluminum alloy shell. Closer shall be non-handed, surface mounted by 3/4" hole spacing and project no more than 3" from the surface of the door. Closer shall have two non-critical thermostatic valves to separately control sweep and latch speeds and provide constant closing speeds even under extreme temperatures. Hydraulic fluid shall be non-gumming and non-freezing. Standard arm bracket shall allow 15% power adjustment. Closer shall be supplied with all necessary mounting fasteners. **OPTIONAL:** All CCL 1050 series closers shall have an independent adjustable backcheck valve to control the cushioning effect in the door's opening cycle.

## SELECTION GUIDE

CLOSER SIZE	DOOR TYPE	MAXIMUM DOOR WIDTH	DOOR WEIGHT RANGE	BACKCHECK	HOLD OPEN	DELAYED ACTION	BARRIER FREE	COVER
52	Interior	914mm (36")	25-40 kg (55-100 lbs)	N/A	152	N/A	N/A	N/A
	Exterior	813mm (32")						
53	Interior	1067mm (42")	40-66 kg (88-145 lbs)	1053	153	N/A	N/A	N/A
	Exterior	914mm (36")						
54	Interior	1219mm (48")	57-86 kg (125-190 lbs)	1054	154	N/A	N/A	N/A
	Exterior	1067mm (42")						
55	Interior	1524mm (60")	80-120 kg (175-265 lbs)	1055	155	N/A	N/A	N/A
	Exterior	1219mm (48")						

## SIZE CHART

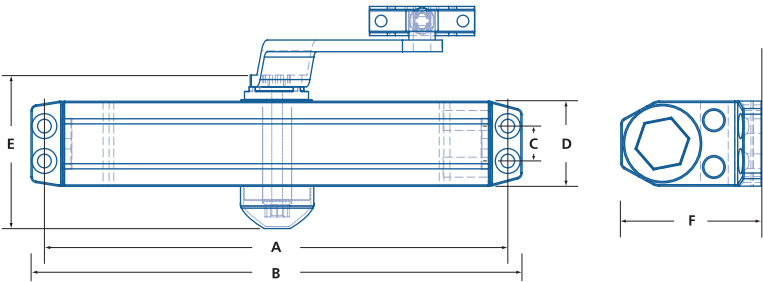
	CLOSER SIZE	52	53	54 / 55
	A	178mm (7")	208mm (8 3/16")	230mm (9 1/16")
	B	195mm (7 11/16")	225mm (8 7/8")	248mm (9 3/4")
	C	19mm (3/4")		
	D	46mm (1 13/16")	46mm (1 13/16")	49mm (1 15/16")
	E	75mm (2 15/16")	85mm (3 3/8")	88mm (3 7/16")
	F	75mm (2 15/16")	75mm (2 15/16")	76mm (3")

## PARTS & ACCESSORIES

	CLOSER SIZE	DESCRIPTION	FINISH	PER CASE	WEIGHT (CASE)
CB54	52	Regular or top jamb mount	AL	10 individually boxed	17.5 kg
DP	53		AL, DU		23.5 kg
SP50	54		AL, DU, BL		24.5 kg
SNB1420	55		AL, DU		29.5 kg
	152		AL		29.5 kg
	1053 / 153	As above with adjustable backcheck / hold open (1053 body size same as 1054)	AL, DU / AL		29.5 kg
	1054 / 154		AL, DU / AL		29.5 kg
	1055 / 155		AL		29.5 kg

CB54

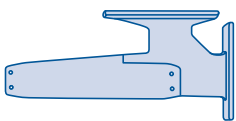

DP



SP50

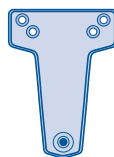

SNB1420



AL – Aluminum DU – Duronodic BL – Black N/A – Not Applicable